

ISUZU GIGAMAX

GIGAMAX 70 - 460

ENGINE		
Model		6WG1-TCS
Type		TURBO CHARGED & INTERCOOLED
Fuel Injection		SITEC COMMON RAIL DIESEL
No. of Cylinders		6
Bore x Stroke	(mm)	147 x 154
Displacement	(cm ³)	15,681
Compression Ratio	(:1)	17.0
Output	(kW @ r/min)	338 @ 1,800
Output	(ps @ r/min)	460 @ 1,800
Torque	(Nm @ r/min)	2,157 @ 1,300
CLUTCH		
Make / Model		SACHS
Type		TWIN DRY PLATES
Diameter	(mm)	390 (15")
Operation		HYDRAULIC WITH AIR ASSIST
SUSPENSION		
Front		TAPER LEAF
Rear		4 BAG AIR / AXLE
BRAKES		
System		FULL AIR
Park Brake		AIR ACTING ON REAR WHEELS
Total Friction Area	(cm ²)	2,400
CAB		
Control		FORWARD
Tilt		ELECTRIC
WHEELS & TYRES		
Type		RADIAL
Tyre Size	(Front)	315/80R22.5
Tyre Size	(Rear)	315/80R22.5
Wheel Size	(Front)	9.00 x 22.5
Wheel Size	(Rear)	9.00 x 22.5
FUEL TANK		
Capacity	(Litres)	1,000
FRONT AXLE		
Model		MERITOR MFS73
REAR AXLE		
Model		MERITOR RT46-160P
Final Drive Ratio	(:1)	4.300
ELECTRICAL SYSTEM		
		24 VOLT
DIMENSIONS (mm)		
OL - Overall Length		6,075
OW - Overall Width		2,490
OH - Overall Height		3,200
WB - Wheelbase		3,950
FOH - Front Overhang		1,400
ROH - Rear Overhang		750
BW - Rear Axle Width		2,500
FT - Front Track		2,065
RT - Rear Track		1,855
EH - Chassis Rear End Height		1,015
CWF - Front Chassis Width		950
CWR - Rear Chassis Width		850
HH - Rear Ground Clearance		240
CE - Cab to Chassis End		-
CA - Cab to Axle		-
GP - Minimum Body Gap		-
MASS DATA (kg)		
Manufacturer's GVM		26,000
Permissible Gross Mass	(V)	25,500
Manufacturer's GCM		70,000
Permissible Combination Mass	(D/T)	70,000
Front Axle Tare Mass		4,904
Rear Axle Tare Mass		3,776
Total Tare Mass		8,680
Gross Axle Mass Load - Front	(GA1)	7,500
Gross Axle Mass Load - Rear	(GA2)	21,000
Permissible Axle Load - Front	(A1)	7,500
Permissible Axle Load - Rear	(A2)	18,000
Tyre Capacity - Front		8,000
Tyre Capacity - Rear		29,200
Approx. Body & Payload		47,320

The smoother model referred to as AMT (Automated Manual Transmission) is an electronically controlled manual transmission, not a full automatic transmission.

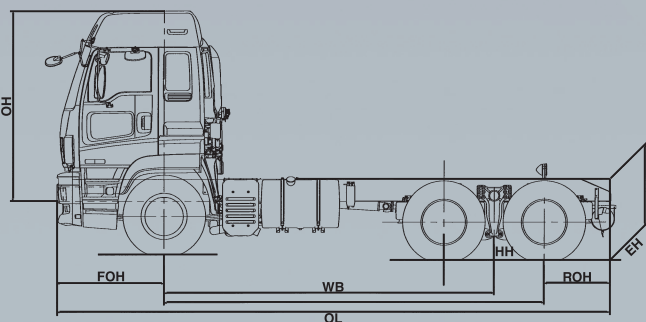
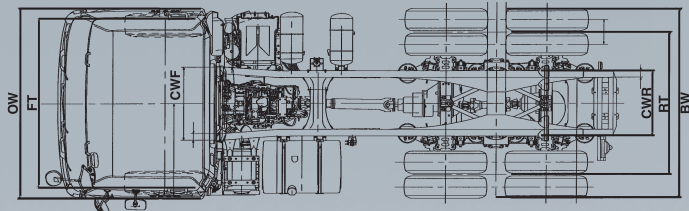

Standard OEM 5th Wheel (Jost 37C) is limited to 65,000kg combination mass.

SEE what we're made of
Introducing the GIGAMAX



ISUZU
TRUCKS
For the long run